



YOUR MUSIC. **YOUR POWER.**

OWNER'S MANUAL
1600.1 EVOX₂

EVOX₂

Introduction	3
Package contents	3
Safety instructions	4
Technologies	
Dynamic Thermal Management (DTM).....	5
Vibration Absorption Device.....	5
Reduced Size.....	5
Full Range	5
Assembling and Disassembling the plastic cover.....	6
Panels description	
Audio inputs and controls.....	7
Power inputs and audio outputs.....	8
Electrical Dimensioning.....	9
RCA input and High Level Input.....	9
Installation sequence.....	10
SD RLC and Gain Setting.....	11
Bass Boost set up.....	12
Crossovers set up.....	12
Wiring Diagram.....	13
Technical specs	
Parameters.....	14
Dimensional data.....	14

DEAR CUSTOMER,**CONGRATULATIONS ON ACQUIRING A PRODUCT WITH THE HIGHEST QUALITY AND TECHNOLOGY!**

You have just purchased a **SoundDigital** product of the highest technology and quality, so we thank you for your confidence.

SoundDigital products are made with raw materials of the highest quality standards, and the most modern processes, equipment and technology are used in their production.

On this manual you will learn about the product, its features and characteristics, in order to obtain the best result and to be able to enjoy your music with **SoundDigital** quality and power.

To better understand and take advantage of all the functions of the product and use it safely, read this manual carefully and if you have any questions, consult our support by email info@sounddigitalusa.com.

PACKAGE CONTENTS

- 1 EVOX2 Amplifier
- 1 Installation quick guide with warranty card
- 1 Allen wrench 2.0mm
- 1 Allen wrench 2.5mm
- 1 Allen wrench 3.0mm
- 1 Promotional sticker

To prevent injuries to the user or damage to the amplifier, read all safety instructions written on this manual;

If you are insecure about the installation of this equipment, get in touch with our tech support or with a professional specialized in car audio installation;

Before proceeding with the installation of any electric equipment on your vehicle, unplug the negative (-) terminal of the battery to avoid fires, injuries or damages;

Use your sound system safely. The continuous exposure to sound pressures over 85dB may cause irreversible hearing damage;

This equipment is for use in automotive DC voltage batteries between 12.6 and 14.4 volts. Before installing the equipment, check voltage of the batteries;

Do not install the amplifier in places exposed to water, dirt or humidity;

Choose a ventilated place to install the amplifier and avoid blocking the side ventilation windows;

Mount the amplifier in a secure way. Avoid mounting it on metallic parts of the vehicle, because it may cause ground looping (noise);

Make sure that the location chosen for the amplifier installation does not effect the operation of the vehicle;

When passing cables through metallic walls, use rubber O-rings to avoid cable cutting and short-circuits.

Clean the amplifier periodically with brush or dry cloth to assure the thermal efficiency of the heatsink.

This product may reach temperatures over 60°C/140°F. Make sure it is cold before touching it;

Be careful when making holes in the vehicle. Make sure you are not making holes in the fuel tank, brake lines or electrical cables of the vehicle

Make sure the cables are properly secured throughout the installation;

Wear gloves, safety glasses and and all necessary PPE during the installation of SounDigital amplifiers.



Warning!

THIS "WARNING" SIGN ALERTS THE USER OF IMPORTANT INFO. NOT FOLLOWING THIS INSTRUCTIONS MAY CAUSE INJURIES TO THE USER OR DAMAGE TO THE EQUIPMENT.

DYNAMIC THERMAL MANAGEMENT - DTM®

OUR PATENTED DTM® TECHNOLOGY PROVIDES A FASTER HEAT EXCHANGE BETWEEN THE ELECTRONIC COMPONENTS AND THE HEATSINK, INCREASING THE EFFICIENCY OF OUR AMPLIFIERS AND RESULTING IN LOWER DISTORTION LEVELS DURING LONG PLAYING TIME.

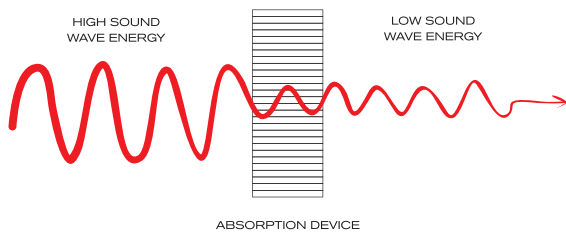

VIBRATION ABSORPTION DEVICE - VAD®

OUR VAD® TECHNOLOGY REDUCES ALL IMPACT CAUSED BY VIBRATION ON THE ELECTRONIC CIRCUIT BOARD. THIS CAN INCLUDE ROAD VIBRATION AND EVEN VIBRATION CAUSED BY SOUND WAVES, INCREASING THE RELIABILITY OF OUR AMPLIFIERS.

REDUCED SIZE

THE TECHNOLOGY USED IN OUR AMPLIFIERS BRING BOTH HIGH PERFORMANCE AND POWER IN A COMPACT CHASSIS, PROVIDING FLEXIBLE INSTALLATION SOLUTIONS FOR VEHICLES WITH LIMITED SPACE.

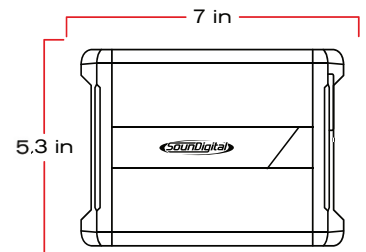

FULL RANGE

AMPLIFIER

FULL RANGE

VERSATILE PRODUCTS THAT COVER THE ENTIRE AUDIBLE FREQUENCY RANGE, ANY TYPE OF LOUDSPEAKER OR MUSIC PROGRAM.

The plastic covers have the function of finishing and hiding the amplifier fixing screws. To disassembling and assembling them, follow the instructions below.

DISASSEMBLING OF THE PLASTIC COVER

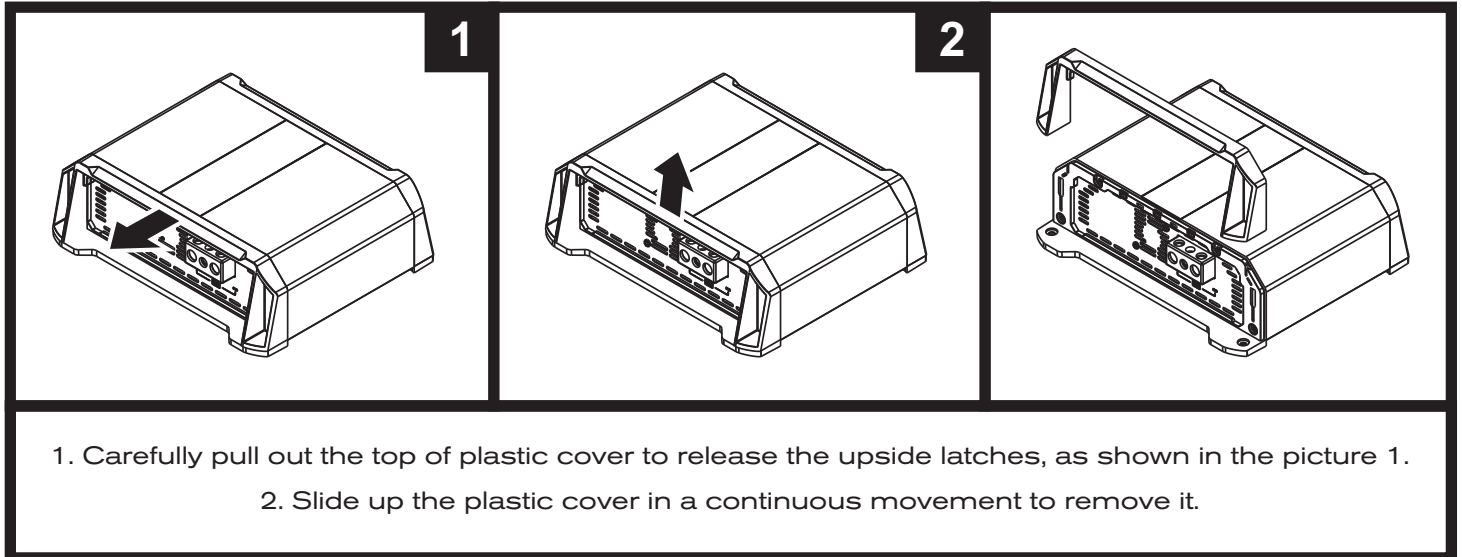

ASSEMBLING THE PLASTIC COVER

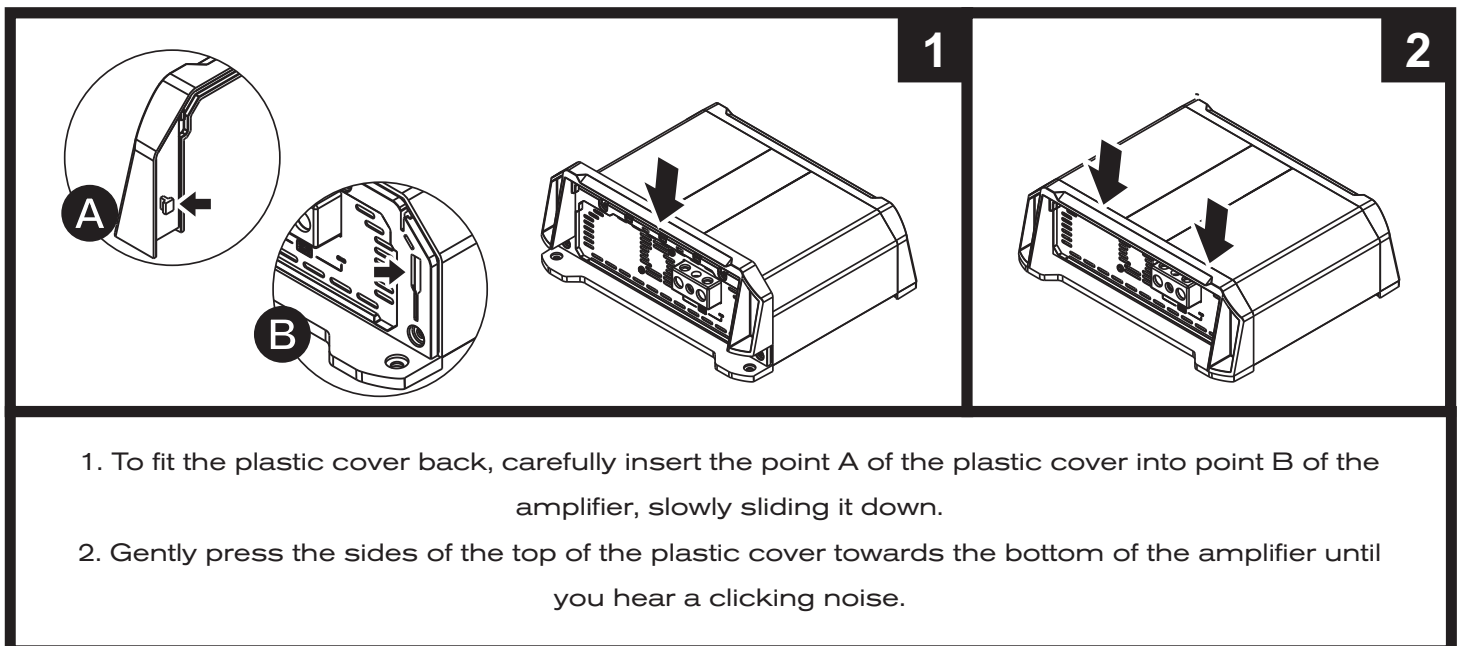

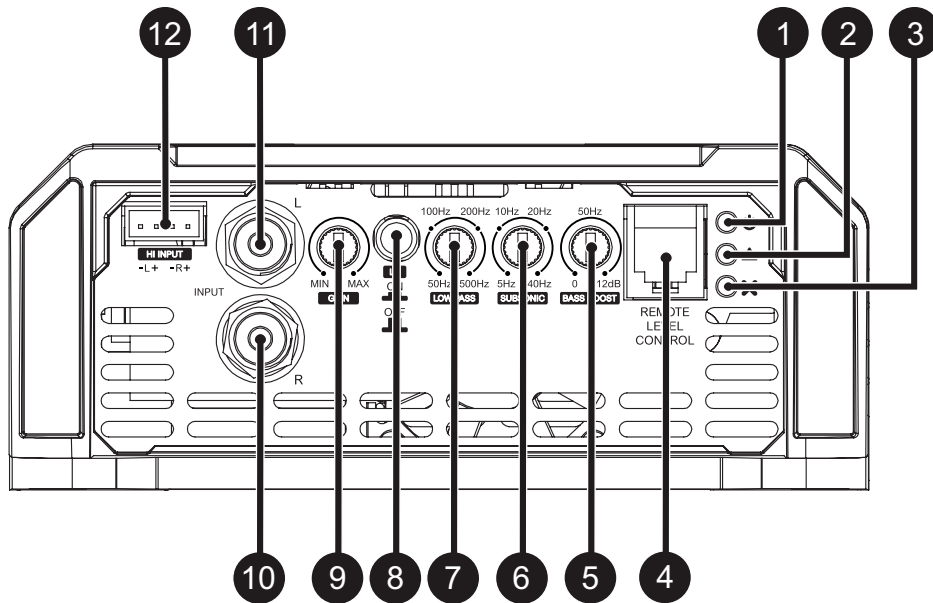

1	Blue	"Power ON" LED indicator
2	Yellow	"Clip" LED indicator
3	Red	"Protection" LED indicator
4	-	Remote level control connector
5	-	Variable Bass Boost Control 50Hz (0dB ~ +12dB)
6	-	Variable Subsonic filter control (5Hz ~ 30Hz)
7	-	Variable Low Pass filter control (50Hz ~ 500Hz)
8	-	Low Pass filter on/off switch key
9	-	Variable Gain control
10	Right Channel	Audio input - RCA connector
11	Left Channel	Audio input - RCA connector
12	Right Channel Left Channel	High Level audio input (To connect to the speaker output of the headunit)

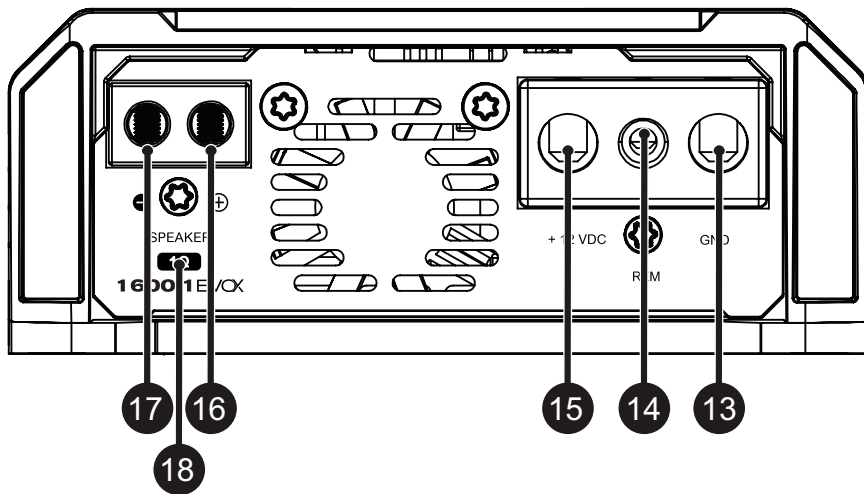

13	-	Negative power supply connector (GND)
14	-	Remote power supply connector (REM)
15	-	Positive power supply connector (+12VDC)
16	Speaker Output Connector	Positive speaker connector
17		Negative speaker connector
18	-	Minimum speaker load allowed (impedance)

ELECTRICAL DIMENSIONING

For proper operation of your SoundDigital amplifier, you need the proper dimensioning of the electrical system and the cables used.

The table below shows the minimum section of GND cables, +12VDC cables and speaker output cables according to the power generated by the amplifier.

1600 WRMS	POWER CABLE	16mm ² - 5 AWG
	GROUND CABLE	
	SPEAKER CABLE	2 x 1.5mm ² - 15 AWG

We recommend the use of ONLY OFC (Oxygen Free Copper) Cables on the installation of our products.

AUDIO INPUTS

RCA Inputs

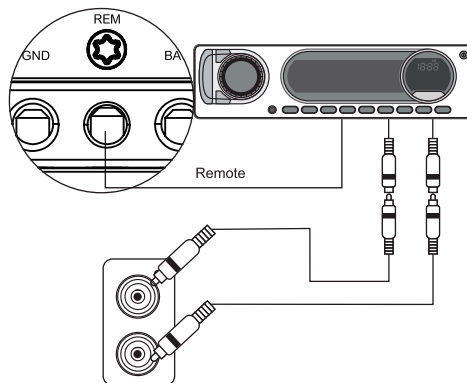

All RCA Inputs must be connected for the channel work.

High Level Input

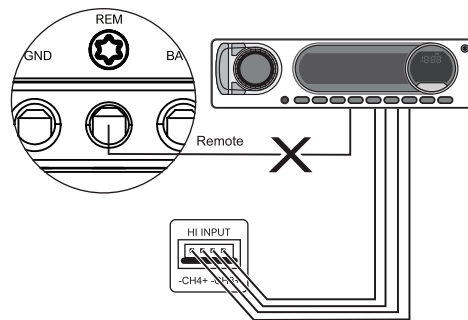

All high level input must be connected for the channel work.

High input must be used when the main unit does not have RCA outputs.

When hi inputs is used, no remote connection is required, the amplifier recognizes the audio signal and switches on.

If your source unit is not able to turn on the amplifier through the high level input, the remote input should be connected normally.



Warning! RCA AND HIGH INPUTS SHOULD NOT BE USED SIMULTANEOUSLY OR YOU MAY DAMAGE THE AMPLIFIER.

**Warning!**

BEFORE PROCEEDING WITH THE INSTALLATION, UNPLUG THE NEGATIVE TERMINAL FROM ALL OF THE BATTERIES, TO AVOID FIRE, DAMAGE TO THE AMPLIFIER AND THE USER HIMSELF.

- Mount the amplifier in such a way you have access to the connectors;
- Install the power cables in the vehicle properly, starting from the battery to the fuse holder or circuit breaker, use the cable with the appropriate size. Make all connections, install fuse holders or circuit breakers, but without placing the fuses or with the circuit breakers in the "Off" position.

**Warning!**

THE MAX. DISTANCE FOR THE INSTALLATION OF THE FUSE/CIRCUIT BREAKER IS ONE FOOT (30 CM) AWAY FROM THE BATTERY.

- Connect the power cables in to the amplifier, observing the polarity. Connect all the positive cables from the fuse holder or circuit breaker to the positive connector of the amplifier and all the negative power cables from the batteries to the negative connector of the amplifier;
- The ground cable must be as short as possible and must be connected to the vehicle chassis and the battery negative;

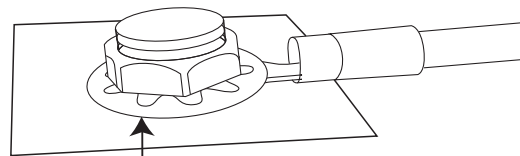

Remove the paint between the terminal and chassis

- Install the signal input cables in a proper way, distant from the power cables;
- Connect the RCA or the high signal input cables to the head unit and amplifiers;
- Install the audio output cables with the appropriate section, distant from the power and audio input cables;
- Connect the audio output cables to the amplifier and speakers respecting the positive (+) and negative (-) polarities;
- Install the remote cable with the power cables, using 1.5mm² (15 AWG) cable or thicker;
- Connect the remote power cable to the amplifier's "REM" terminal at the main unit's remote power output (when not using the high level signal inputs);
- Before powering the system, verify all the connections and make sure there are no mistakes or short-circuits on the power and ground cables;
- Reconnect the ground of the batteries;
- Check if the headunit is turned off and then place the fuses in the fuse holders or switch the circuit breakers on;
- Turn on the main unit and the amplifier will turn on the "On" LED indicating that it is in operation.

Gain setting

Necessary equipment:

- Digital AC voltmeter;
- Media with sine wave test tone 60Hz recorded at 0db;
- Screwdriver 1/8" (for gain set)
- Use a 60 Hz sine wave
- Increase the gain control until the "CLIP" LED starts blinking;
- Return the gain to the limit where the "CLIP" LED stops blinking and remains off;

Set up procedure

- Turn the gain control all the way down.
- Disconnect the output cables from the amplifier outputs;
- Turn off all processing (bass, treble, loudness, EQ, etc.);
- Set the source unit volume to 3/4 of full volume.
- Set the source unit's fader control to center position;
- Set the variable "LOW" crossover in 500Hz and the "SUBSONIC" in 5Hz;

- Once you have adjusted the amplifier to its correct voltage output, turn off the source unit and reconnect the speaker(s)

Download the tracks for set up in <https://sounddigitalusa.com/tracks-for-set-up/>

External Level Control - SD RLC (not included)

The SD RLC is an easy-to-install external level control accessory that allows you to tune the level of SOUNDIGITAL amplifiers that have remote level control.

In SD RLC, you can adjust the amplifier level without having to lean over and adjust the gain setting on the amplifier and can monitor the "CLIP" LED which is also available on the accessory.

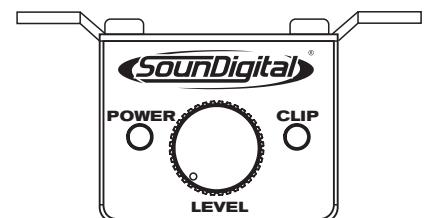

**SD REMOTE
LEVEL CONTROL***

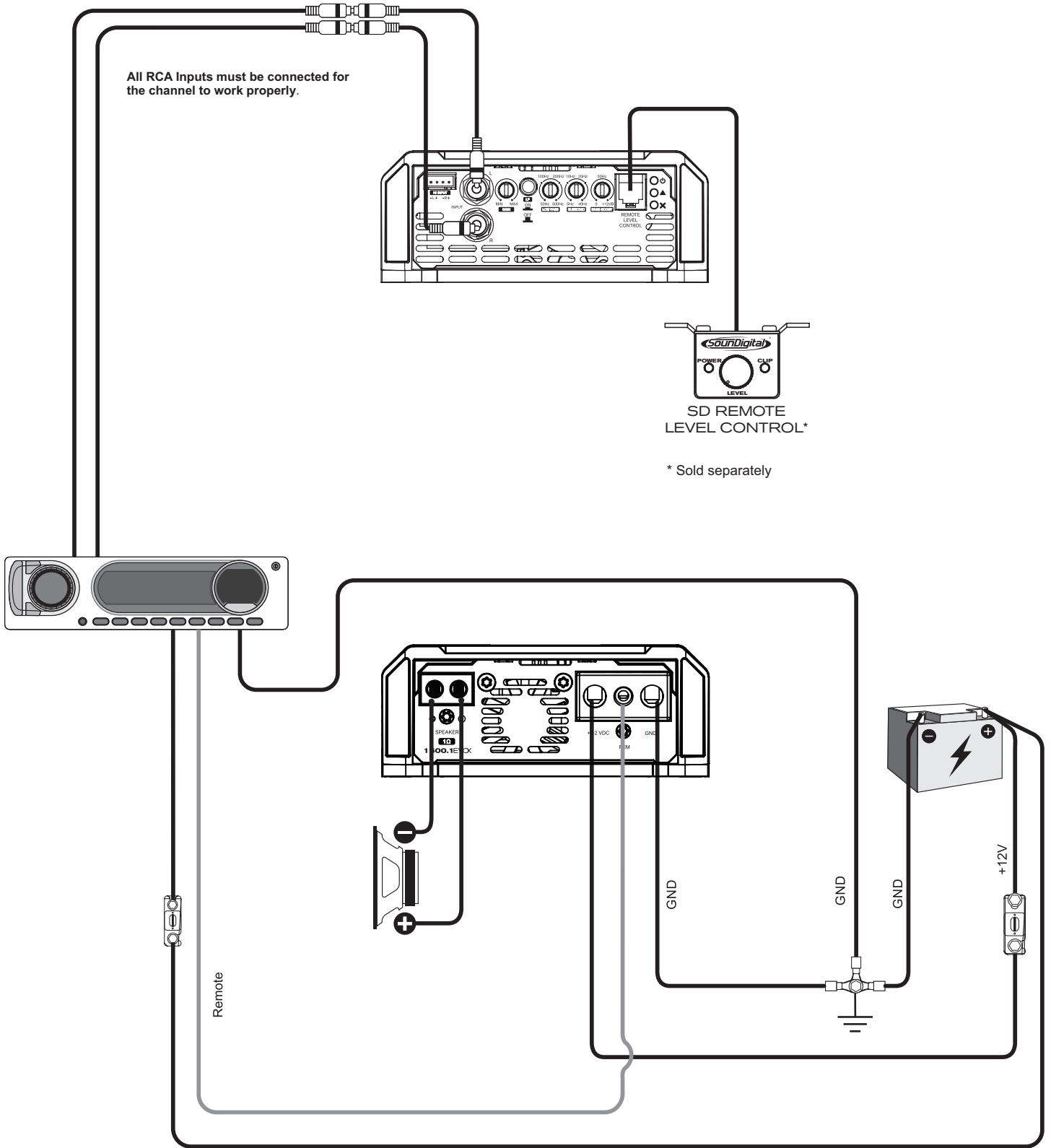

PARAMETER	1600.1EVOX ₂ - 1Ω	1600.1EVOX ₂ - 2Ω
RMS Power @ 4Ω	697W	1056W
RMS Power @ 2Ω	1056W	1600W
RMS Power @ 1Ω	1600W	N/A
Frequency response	5Hz ~ 25kHz	5Hz ~ 25kHz
Subsonic	5Hz ~ 40Hz	5Hz ~ 40Hz
Low pass filter	50Hz ~ 500Hz	50Hz ~ 500Hz
Bass boost	0dB ~ 12dB @ 50Hz	0dB ~ 12dB @ 50Hz
Operating voltage	8V ~ 16V	8V ~ 16V
SNR	94dB	94dB
Input sensitivity	0.2V ~ 4V	0.2V ~ 4V
Current draw (music)	62A	62A
Current draw (Max)	125A	125A
Total efficiency	89%	89%
Damping factor	>2000	>2000
Power cable	16mm ² (5AWG)	16mm ² (5AWG)
Speaker Cable	2 x 1.5 mm ² 15 AWG	2 x 1.5 mm ² 15WG
Recommended Fuse (music)*	70A	70A
Recommended battery	90Ah	90Ah



REAL POWER NUMBERS
CTA-2006 INDUSTRY STANDARDS

*It is mandatory to install the fuse at a maximum distance of 12 inches from the battery.

DIMENSIONAL DATA

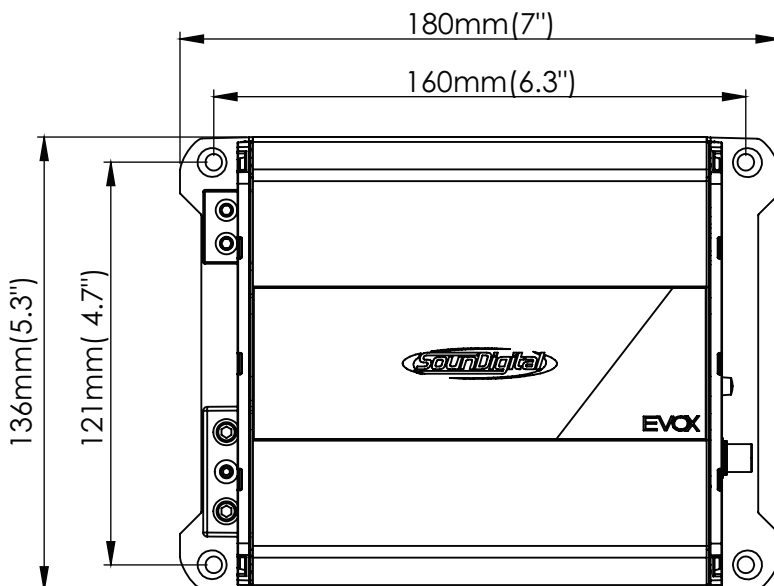

Net Weight: 2.4lb (1.1Kg)
Gross Weight: 2.9lb (1.3Kg)

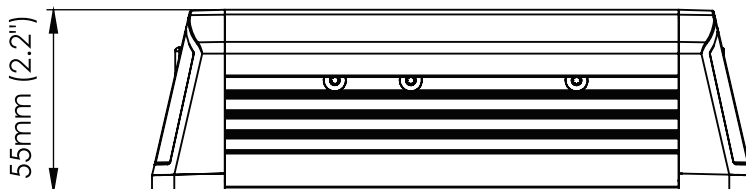



YOUR MUSIC. **YOUR POWER.**



Consumer
Technology
Association™



WWW.SOUNDIGITAL.COM



[SOUNDIGITALUSA](https://www.facebook.com/SOUNDIGITALUSA)



[SOUNDIGITALUSA](https://www.instagram.com/SOUNDIGITALUSA)