



YOUR MUSIC. **YOUR POWER.**

OWNER'S MANUAL
8000.1 EVOX₂

EVOX₂

Introduction	3
Package contents	3
Safety instructions	4
Technologies	
DTM®	5
I-Power Supply	5
Vibration Absorption Device.....	6
Reduced size.....	6
Assembling and Disassembling the plastic cover.....	7
Panels description	
Audio inputs and controls	8
Power inputs and audio outputs	9
Installation sequence.....	10
Electrical Dimensioning.....	11
Audio inputs	
RCA inputs	11
High Level inputs	11
Wiring diagram.....	12
SD RLC and procedure for setting the gain	13
Bass Boost set up	14
Crossovers set up	14
Technical specifications	
Parameters	15
Dimensional data.....	15

DEAR CUSTOMER,**CONGRATULATIONS ON ACQUIRING A PRODUCT WITH THE HIGHEST QUALITY AND TECHNOLOGY!**

You have just purchased a SounDigital product of the highest technology and quality, so we thank you for your confidence.

Class D Amplifiers:

Class D amplifiers have as main characteristics the audio quality, efficiency, application versatility and compact design. Following are the advantages of these features:

Audio Quality – In the past, Class D products had limited response and for higher frequencies, Class AB products performed better, but their efficiency was very low. The new technologies introduced by SounDigital resulted in a Class D amplifier with high efficiency and superior Class AB performance.

Efficiency – SounDigital Class D amplifiers have total efficiency (output + power source) greater than 70%, which guarantees lower battery consumption and less heating.

Application Versatility – The flat full-frequency response of SounDigital amplifiers allows them to be used in all car sound systems. Meeting the demands with extreme quality.

Compact Design – The high efficiency and high technology applied, allows SounDigital amplifiers to be very compact, facilitating installation in vehicles where space is limited.

IMPORTANT INFORMATIONS

On this manual you will learn about the product, its features and characteristics, in order to obtain the best result and to be able to enjoy your music with SounDigital quality and power.

To better understand and take advantage of all the functions of the product and use it safely, read this manual carefully and if you have any questions, consult our support by email: **info@soundigitalusa.com**.

PACKAGE CONTENTS

- 01 **8000.1 EVOX2** Amplifier
- 01 Installation quick guide with warranty card
- 01 Allen wrench 2.5mm
- 01 Allen wrench 4.0mm
- 01 Promotional sticker

To prevent injuries to the user or damage to the amplifier, read all safety instructions written on this manual;

If you are insecure about the installation of this equipment, get in touch with our tech support or with a professional specialized in car audio installation;

Before proceeding with the installation of any electric equipment on your vehicle, unplug the negative (-) terminal of the battery to avoid fires, injuries or damages;

Use your sound system safely. The continuous exposure to sound pressures over 85dB may cause irreversible hearing damage;

This equipment is for use in automotive DC voltage batteries between 12.6 and 14.4 volts. Before installing the equipment, check voltage of the batteries;

Do not install the amplifier in vehicle engine compartment, places exposed to water, dirt or humidity;

Choose a ventilated place to install the amplifier and avoid blocking the side ventilation windows;

Mount the amplifier in a secure way. Avoid mounting it on metallic parts of the vehicle, because it may cause ground looping (noise);

When passing cables through metallic walls, use rubber O-rings to avoid cable cutting and short-circuits;

Make sure that the location chosen for the amplifier installation does not effect the operation of the vehicle;

This product may reach temperatures over 60°C/140°F. Make sure it is cold before touching it;

Clean the amplifier periodically with brush or dry cloth to assure the thermal efficiency of the heatsink;

Be careful when making holes in the vehicle. Make sure you are not making holes in the fuel tank, brake lines or electrical cables of the vehicle;

Make sure the cables are properly secured throughout the installation;

Wear gloves, safety glasses and and all necessary PPE during the installation of SounDigital amplifiers.



Warning!

THIS "WARNING" SIGN ALERTS THE USER OF IMPORTANT INFO. NOT FOLLOWING THIS INSTRUCTIONS MAY CAUSE INJURIES TO THE USER OR DAMAGE TO THE EQUIPMENT.

DYNAMIC THERMAL MANAGEMENT - DTM®

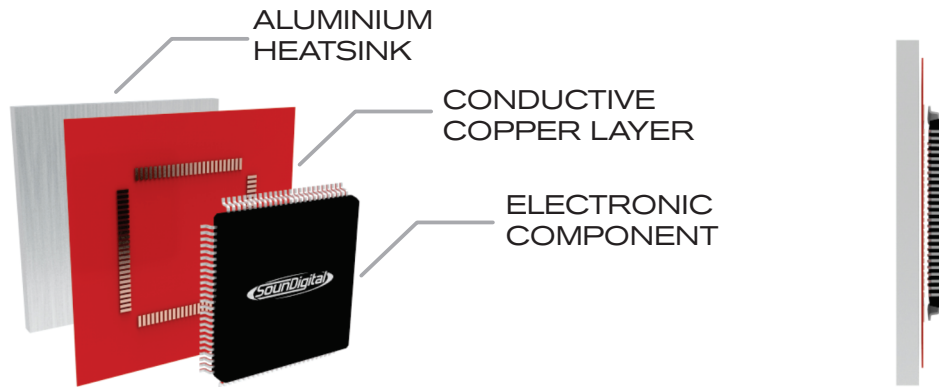

The **DTM*** is a dynamic thermal recovery system which always maintains a high efficiency of the amplifier by accelerating the thermal exchange of electronic components with the heatsink.

* Patent. Required

ULTRA COMPACT PCB

An intelligent layout, with great use of the PCB area and the use of modern components with reduced structure guarantee **SoundDigital** products a compact design, at the same time robust and with excellent thermal efficiency.

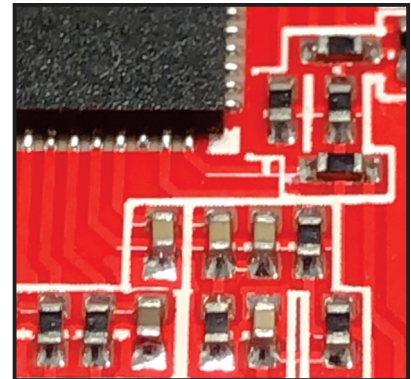

I-POWER SUPPLY

SoundDigital amplifiers are known for their low consumption of battery, and this feature was improved on the **EVOX2 Line**. The new **I-POWER SUPPLY** is even more modern, which replaces the old toroidal transformers by a new generation of "E-E" core transformers delivers efficiency above 90%*, ensuring more hours of sound without battery recharge.

*Efficiency measured at power supply only



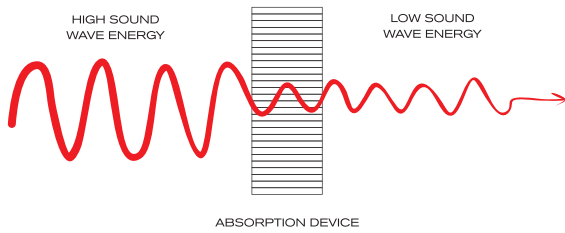

VIBRATION ABSORPTION DEVICE - VAD®

Our VAD® Technology reduces all impact caused by vibration on the electronic circuit board. This can include road vibration and even vibration caused by sound waves, increasing the reliability of our amplifiers.

REDUCED SIZE

The technology used in our amplifiers bring both high performance and power a compact chassis, providing flexible installation solutions for vehicles with limited space.

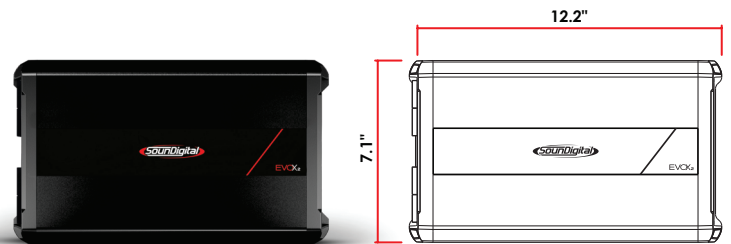

FULL RANGE

AMPLIFIER

FULL RANGE

Versatile products that cover the entire audible frequency range, any type of loudspeaker or music program.

The plastic covers have the function of finishing and hiding the amplifier fixing screws. To disassembling and assembling them, follow the instructions below.

DISASSEMBLING OF THE PLASTIC COVER

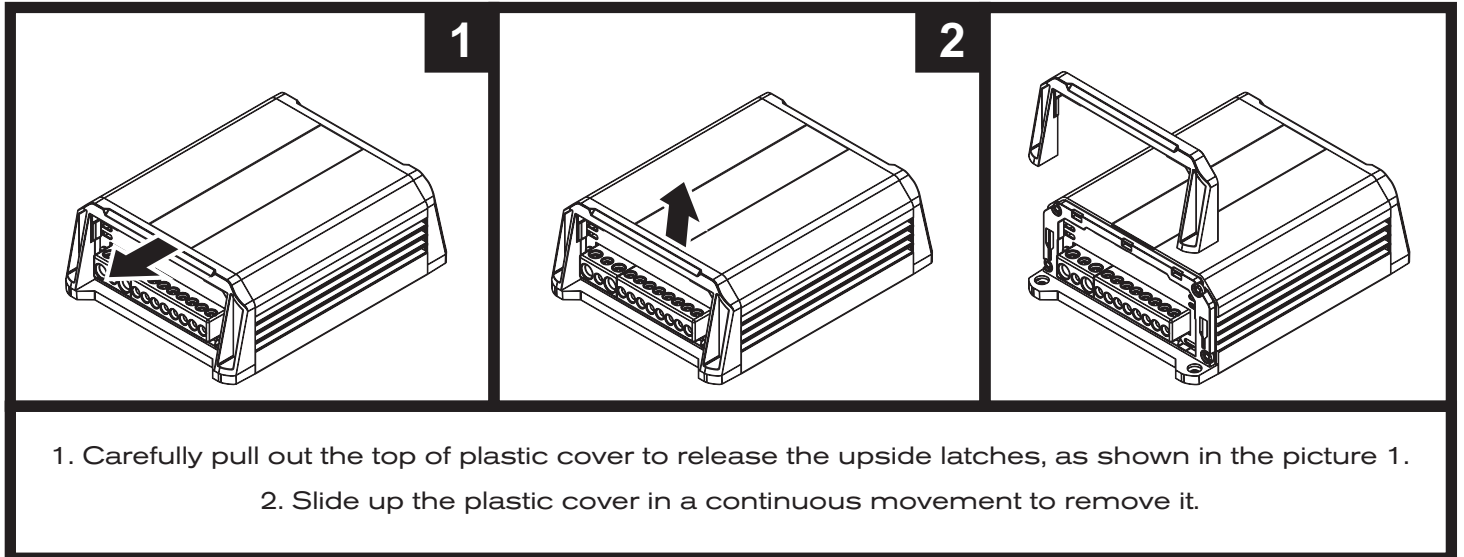

*Merely illustrative images.

ASSEMBLING THE PLASTIC COVER

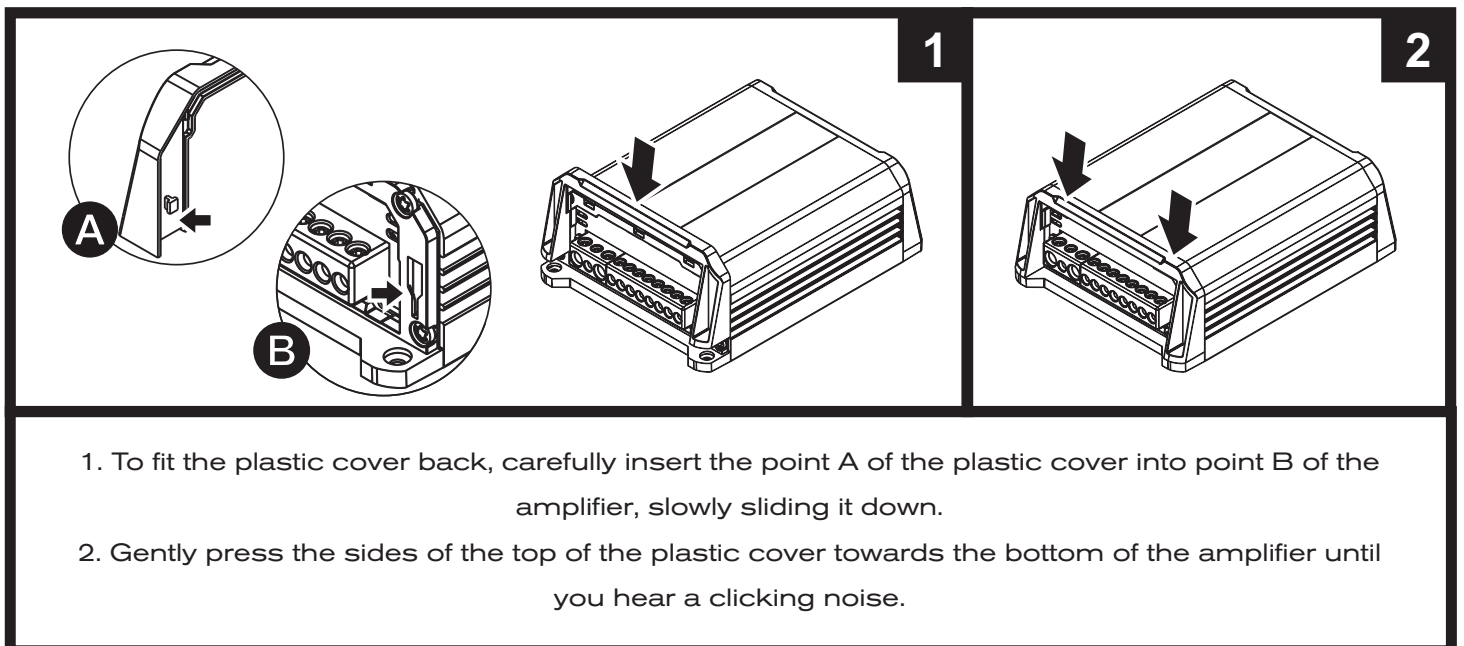

*Merely illustrative images.

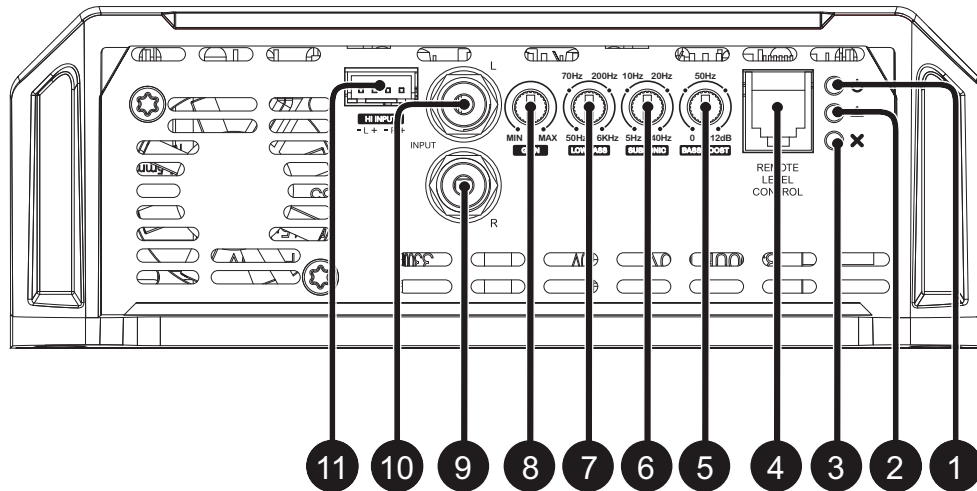

1	Blue	"Power ON" LED indicator
2	Yellow	"Clip" LED indicator
3	Red	"Protection" LED indicator
4	-	Remote level control connector
5	-	Variable Bass Boost Control 50Hz (0dB ~ +12dB)
6	-	Variable Subsonic filter control (5Hz ~ 40Hz)
7	-	Variable Low Pass filter control (50Hz ~ 6kHz)
8	-	Variable Gain control
9	Right Channel	Audio inputs – RCA connectors
10	Left Channel	
11	Right Channel Left Channel	Audio input – High Level (To connect to the speaker output of the head unit)

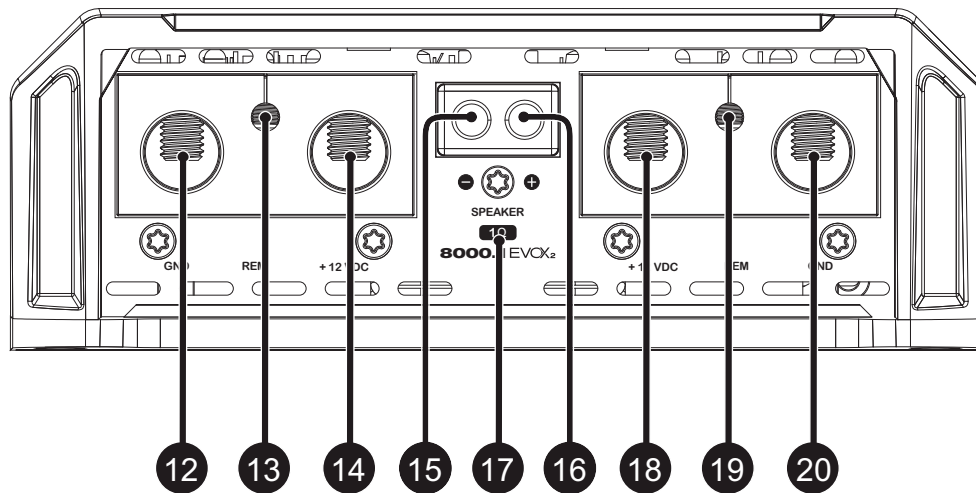

12	-	Negative power supply connector (GND)
13	-	Remote power supply connector (REM)
14	-	Positive power supply connector (+12VDC)
15	Speaker Output Connectors	Negative speaker connector
16		Positive speaker connector
17	-	Minimum speaker load allowed (impedance)
18	-	Positive power supply connector (+12VDC)
19	-	Remote power supply connector (REM)
20	-	Negative power supply connector (GND)

**Warning!**

BEFORE PROCEEDING WITH THE INSTALLATION, UNPLUG THE NEGATIVE TERMINAL FROM ALL OF THE BATTERIES, TO AVOID FIRE, DAMAGE TO THE AMPLIFIER AND THE USER HIMSELF.

- Mount the amplifier in such a way you have access to the connectors;
- Install the power cables in the vehicle properly, starting from the battery to the fuse holder or circuit breaker, use the cable with the appropriate size. Make all connections, install fuse holders or circuit breakers, but without placing the fuses or with the circuit breakers in the "OFF" position;

**Warning!**

THE MAXIMUM DISTANCE FOR THE INSTALLATION OF THE FUSE/CIRCUIT BREAKER IS 12 INCHES (30cm) AWAY FROM THE BATTERY.

- Connect the power cables in to the amplifier, observing the polarity. Connect all the positive cables from the fuse holder or circuit breaker to the positive connector of the amplifier and all the negative power cables from the batteries to the negative connector of the amplifier;
- The ground cable must be as short as possible and must be connected to the vehicle chassis and the battery negative;

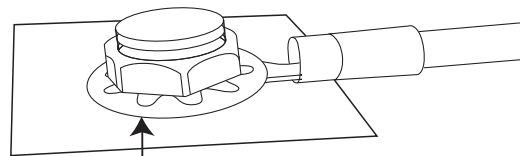

Remove the paint between the terminal and chassis

- Install the signal input cables in a proper way, distant from the power cables;
- Connect the RCA or the high level signal input cables to the head unit and amplifiers;
- Install the audio output cables with the appropriate section, distant from the power and audio input cables;
- Connect the audio output cables to the amplifier and speakers respecting the positive (+) and negative (-) polarities;
- Install the remote cable with the power cables, using 1.5mm² (15 AWG) cable or thicker;
- Connect the remote power cable to the amplifier's "REM" terminal at the main unit's remote power output (when not using the high level signal inputs);
- Before powering the system, verify all the connections and make sure there are no mistakes or short-circuits on the power and ground cables;
- Reconnect the ground of the batteries;
- Check if the head unit is turned off and then place the fuses in the fuse holders or switch the circuit breakers on;
- Turn on the main unit and the amplifier will turn on the "POWER ON" LED indicating that it is in operation.

ELECTRICAL DIMENSIONING

For proper operation of your SounDigital amplifier, you need the proper dimensioning of the electrical system and the cables used.

The table below shows the minimum section of GND cables, +12VDC cables and speaker output cables according to the power generated by the amplifier.

8000 WRMS	POWER CABLE GROUND CABLE	70mm ² (00 AWG)
	SPEAKER CABLE	2 x 6mm ² (9 AWG)

We recommend the use of ONLY OFC (Oxygen Free Copper) Cables on the installation of our products.

AUDIO INPUTS

RCA inputs

Example of one RCA cable connection only

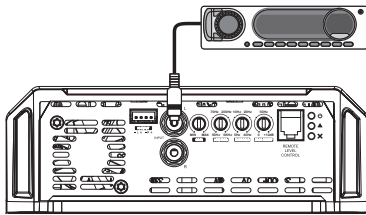

Example of two RCA cables connection (mono input).

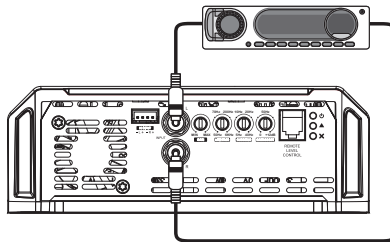

Example of one RCA cable connection only and using the RCA output to connect another amplifier.

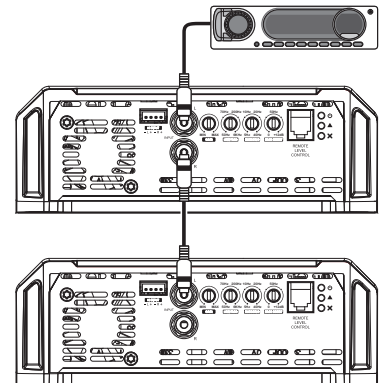

All RCA inputs must be connected for the channel to work properly.

High level signal inputs

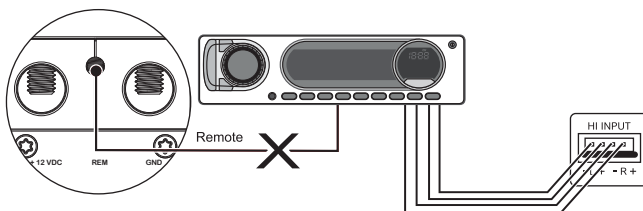

All High level signal Inputs must be connected for the all channels to work properly.

High level input must be used when the main unit does not have RCA outputs.

When High level inputs is used, no remote connection is required, the amplifier recognizes the audio signal and switches on.

If your source unit is not able to turn on the amplifier through the High level input, the remote input should be connected normally.



Warning!

RCA AND HIGH LEVEL INPUTS SHOULD NOT BE USED SIMULTANEOUSLY OR YOU MAY DAMAGE THE AMPLIFIER.



Unplug the negative (-) terminal of the battery before proceeding with any electrical installation in the vehicle to avoid fire starts, wounds or damage to the amplifier.

POWER CONNECTIONS

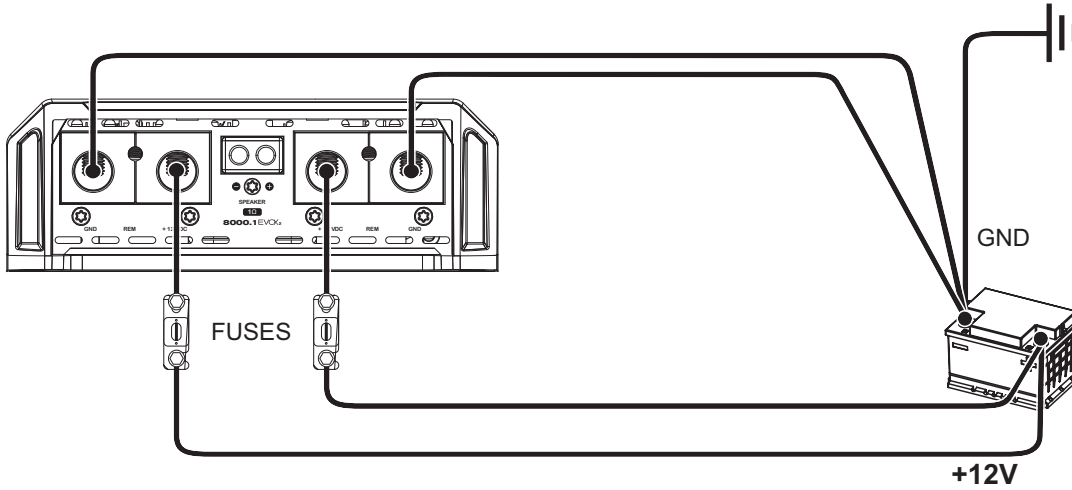

REMOTE INPUT CONNECTIONS

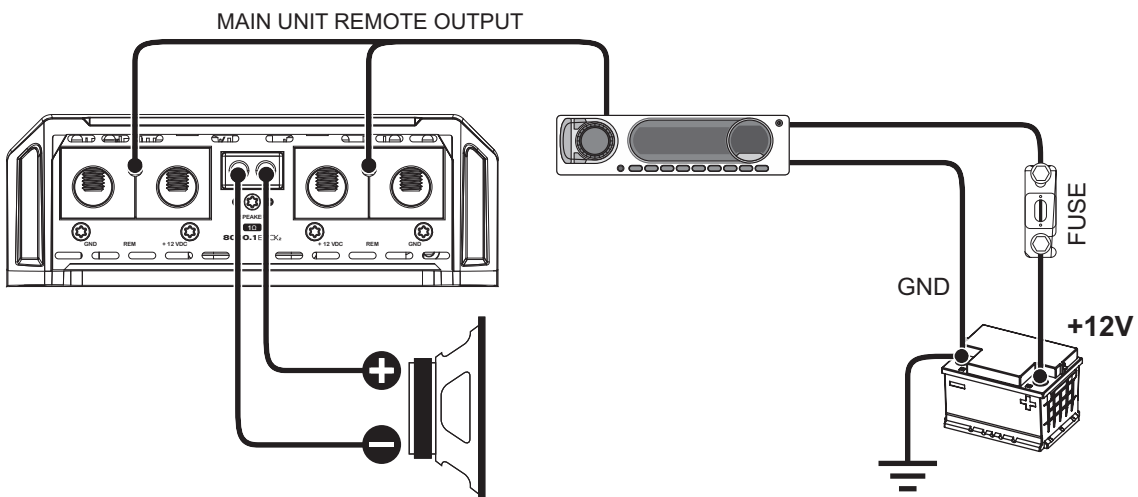

AUDIO INPUT AND OUTPUT CONNECTIONS

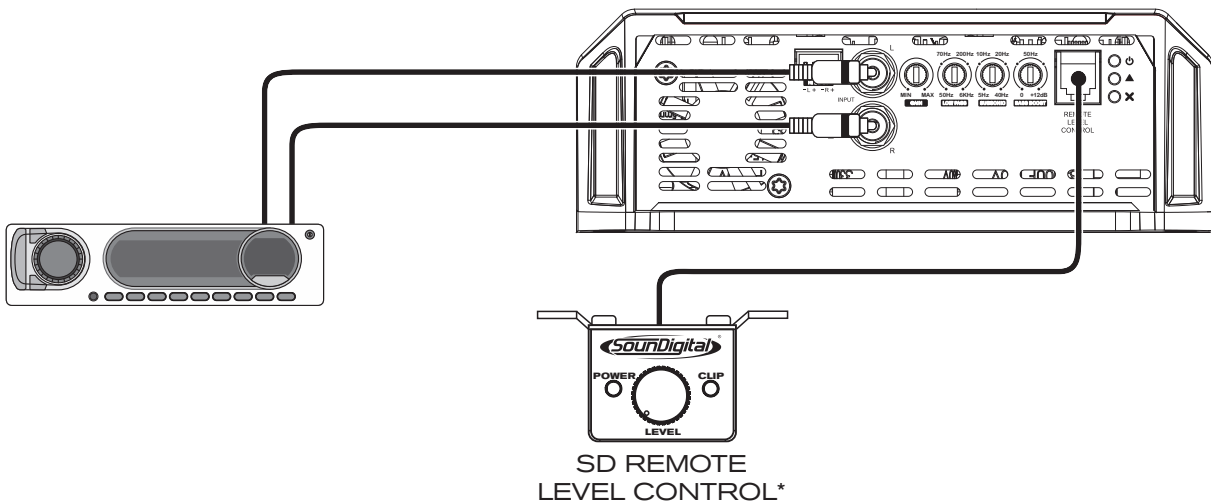

SD REMOTE LEVEL CONTROL*

*Sold separately

EXTERNAL LEVEL CONTROL - SD RLC (*Not included)

The SD RLC is an easy-to-install external level control accessory that allows you to tune the level of SOUNDIGITAL amplifiers that have remote level control.

In SD RLC, you can adjust the amplifier level without having to lean over and adjust the gain setting on the amplifier and can monitor the "CLIP" LED which is also available on the accessory.

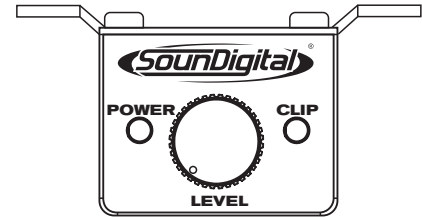

SD REMOTE
LEVEL CONTROL*

*Sold separately

GAIN SETTING

Necessary equipment:

- Digital AC voltmeter;
- Media with sine wave test tone 60Hz recorded at 0dB;
- Screwdriver 1/8" (for gain set);
- On the audio player, set the fader control to center position;
- Set the variable "LOW PASS" crossover in 6kHz and the "SUBSONIC" in 5Hz;

Set up procedure:

- Turn the gain control all the way down;
- Disconnect the output cables from the amplifier outputs;
- Turn off all processing (bass, treble, loudness, EQ, etc.);
- Set the source unit volume to 3/4 of full volume;
- Use a 60Hz sine wave;
- Increase the gain control until the "CLIP" LED starts blinking;
- Return the gain to the limit where the "CLIP" LED stops blinking and remains off;
- Once you have adjusted the amplifier to the correct voltage output, turn off the source unit and reconnect the speaker(s).

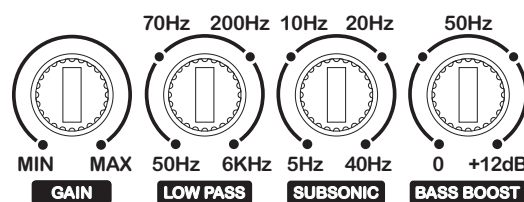

Download the tracks for set up in <https://sounddigitalusa.com/tracks-for-set-up/>

Using Bass Boost

The Amplifier Bass Boost setting enables the user to boost the sound intensity at low frequencies of the sound system, where boost intensity can be adjusted.

This is a semi-parametric equalizer type circuit with "Q" value for the fixed filter, with an intensity boost adjustment from 0 to +12dB (16 times), and a central frequency adjustment of the filter in 50Hz, making it versatile for several types of sound systems.

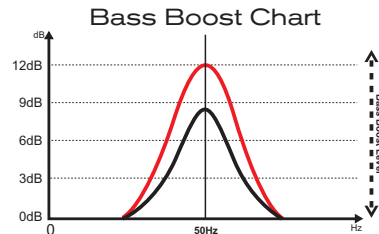

How to Adjust Bass Boost

Reproduce your favorite song and set the boost intensity between 0dB and +12dB at the variable control level according your preference.

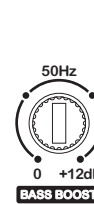

How to Adjust the Crossovers

The use of the two associated filters can form a bandpass filter, as in the figure below, where the point "A" is defined in the "SUBSONIC" crossover and the point "B" is defined in the "LOW PASS" crossover.

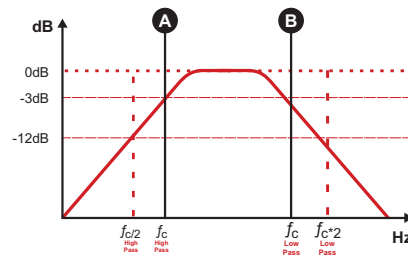
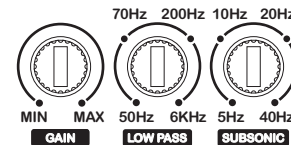

To set the "SUBSONIC" variable control between 5Hz and 40Hz ("A") where you want to perform the subsonic cut filter;

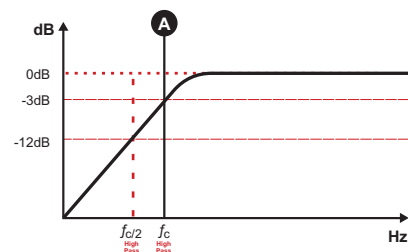

Set in the "LOW PASS" variable control between 50Hz and 6kHz ("B") where you want to perform the low pass cut filter;

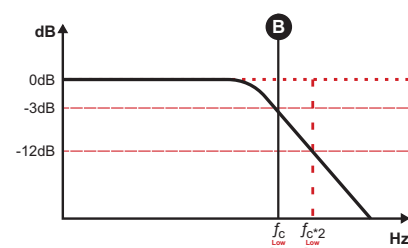

PARAMETERS	8000.1EVOX ₂ 1Ω	8000.1EVOX ₂ 2Ω
Power RMS @ 4Ω**	3485W	5280W
Power RMS @ 2Ω**	5280W	8000W
Power RMS @ 1Ω**	8000W	N/A
Frequency response (-3dB)	5Hz ~ 6kHz	5Hz ~ 6kHz
Subsonic (12dB/oct)	5Hz ~ 40Hz	5Hz ~ 40Hz
Low pass filter (12dB/oct)	50Hz ~ 6kHz	50Hz ~ 6kHz
Bass Boost	0dB ~ 12dB @ 50Hz	0dB ~ 12dB @ 50Hz
Operating voltage	8V ~ 16V	8V ~ 16V
SNR	82dB	82dB
Input sensitivity (RCA)	0.19V ~ 2.23V	0.19V ~ 2.29V
Input sensitivity (High Level input)	1.32V ~ 15.52V	1.33V ~ 15.99V
Current draw (music)	343A	343A
Current draw (max.)	686A	686A
Total efficiency	81%	81%
Damping factor (@100Hz nominal impedance)	>2000	>2000
Power cable	70mm ² / 00 AWG	70mm ² / 00 AWG
Speaker cable	2 x 6 mm ² / 9 AWG	2 x 6 mm ² / 9 AWG
Recommended Fuse* (music)	400A	400A
Recommended battery (minimum)	400Ah	400Ah

*It is mandatory to install the fuse at a maximum distance of 12 inches from the battery.

**Power at 14.4V @ 60Hz with a maximum THD of 1%.



****POWER RATING ACCORDING TO CTA-2006 INDUSTRY STANDARDS.**

DIMENSIONAL DATA

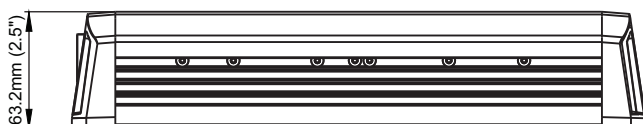
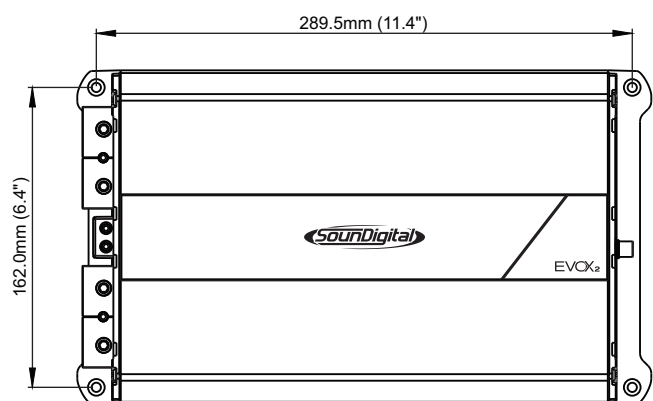
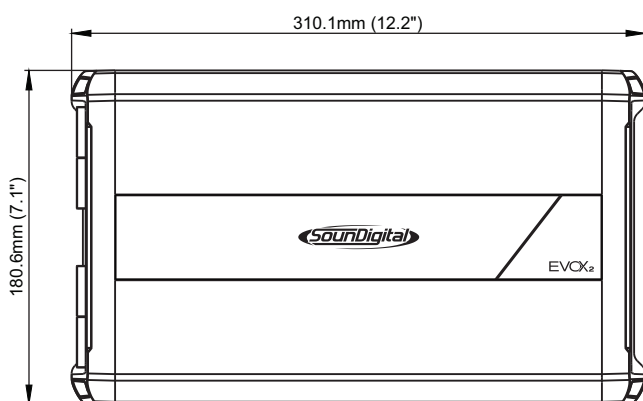

Net Weight	3.70 kg (8.15 lb)
Gross Weight	4.00 kg (8.81 lb)



YOUR MUSIC. **YOUR POWER.**

CODE: 1000750324-001/NOV2022



Consumer
Technology
Association™



WWW.SOUNDIGITALUSA.COM



[SOUNDIGITALUSA](https://www.facebook.com/SOUNDIGITALUSA)



[SOUNDIGITALUSA](https://www.instagram.com/SOUNDIGITALUSA)